

SIR Endec for IrDA Applications Integrated Interface Circuit

ULC Technology: High performance gate array package using multiple metal layer CMOS technology featuring sub-micron channel lengths (0.35 μm).

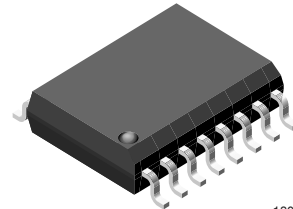

18080

Description

The TOIM4232 Endec IC provides proper pulse shaping for the SIR IrDA[®] front end infrared transceivers as of the 4000-series. For transmitting the TOIM4232 shortens the RS232 output signal to IrDA compatible electrical pulses to drive the infrared transmitter. In the receive mode, the TOIM4232 stretches the received infrared pulses to the proper bit width depending on the operating bit rate. The IrDA bit rate varies from 2.4 kbit/s to 115.2 kbit/s.

The TOIM4232 is using a crystal clock 3.6864 MHz for its pulse stretching and shortening. The clock can be generated by the internal oscillator. An external clock can be used, too. The TOIM4232 is programmable to operate from 1200 bit/s to 115.2 kbit/s by the communication software through the RS232 port. The output pulses are software programmable as either 1.627 μs or 3/16 of bit time. The typical power consumption is very low with about 10 mW in operational state and in the order of a few microwatts in standby mode.

Features

- Pulse shaping function (shortening and stretching) used in SIR IrDA[®] applications
- Directly interfaces the SIR transceiver TFD..-series to an RS232 port
- Programmable baud clock generator (1200 Hz to 115.2 kHz), 13 baud rates
- 3/16 bit pulse duration or 1.627 μs pulse selectable
- SO16 - package
- 2.7 V to 3.6 V operation voltage, 5 V tolerant inputs
- Low operating current

Block Diagram

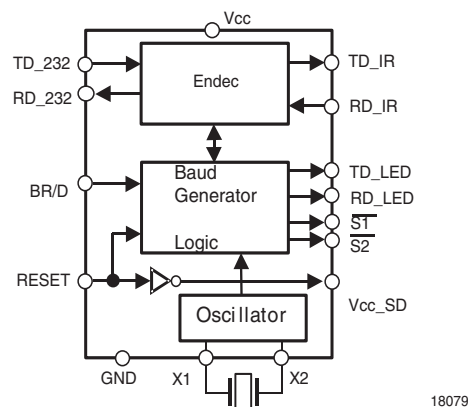

18079

Pin Assignment and Description

Pin Number	Symbol	Description	I/O	Active
1	RESET	Resets all internal registers. Initially must be HIGH ("1") to reset internal registers. When HIGH, the TOIM4232 sets the IrDA default bit rate of 9600 bit/s, sets pulse width to 1.627 μ s. The V_{CC_SD} output is simply an inverted reset signal which allows to shut down of a TFDx4x00 transceiver when applying the reset signal to the TOIM4232. When using devices with external SD like TFDS4203, the reset line can be used directly as shut down signal. RESET pin can be controlled by either the RTS or DTR line through RS232 level converter. Minimum hold time for resetting is 1 μ s. Disables the oscillator when active.		HIGH
2	BR/ D	<p style="text-align: center;">Baud Rate control/ Data.</p> <p style="text-align: center;">BR/ D = 0, data communication mode:</p> RS232 TXD data line is connected (via a level shifter) to TD_232 input pin. The TXD - signal is appropriately shortened and applied to the output TD_IR, driving the TXD input of the IR transceiver. The RXD line of the transceiver is connected to the RD_IR input. This signal is stretched to the correct bit length according the programmed bit rate and is routed to the RS232 RXD line at the RD_232 pin. <p style="text-align: center;">BR/ D = 1, Programming mode:</p> Data received from the RS232 port is interpreted as Control Word. The Control Word programs the baud rate width will be effective as soon as BR/ D return to LOW.		
3	RD_232	Received signal data output of stretched signal to the RS232 RXD line (using level converter).	O	HIGH
4	TD_232	Input of the signal to be transmitted from the RS232 port TXD line (passing the level converter).	I	HIGH
5	V_{CC_SD}	Outputs an inverted RESET signal. Can be used to shut down the power supply of a 4000 series transceiver (e.g., TFDU4100). V_{CC} shutdown output function. This pin can be used to shut down a transceiver (e.g., TFDx4xxx). Output polarity: Inverted RESET input.	O	LOW
6	X1	Crystal input clock, 3.6864 MHz nominal. Input for external clock *)	I	
7	X2	Crystal *)	I	
8	GND	Ground in common with the RS232 port and IrDA transceiver ground		
9	TD_LED	Transmit LED indicator driver. Use 180 Ω current limiting resistor in series to LED to connect to V_{CC} . ($V_{CC} = 3.3$ V)	O	LOW
10	RD_LED	Receive LED indicator driver. Use 180 Ω current limiting resistor in series to LED to connect to V_{CC} . ($V_{CC} = 3.3$ V)	O	LOW
11	NC	No connection		
12	S1	User Programmable Bit. Can be used to turn ON/ OFF a front-end infrared transceiver (e.g., an infrared module at the adapter front)	O	LOW
13	S2	User Programmable Bit. Can be used to turn ON/ OFF a front-end infrared transceiver (e.g., an infrared module at the adapter back)	O	LOW
14	TD_IR	Data output of shortened signal to the infrared transceiver	O	HIGH
15	RD_IR	Data input from the infrared transceiver, min. pulse duration 1.63 μ s **)	I	LOW
16	VCC	Supply voltage	I	

*) Crystal should be connected as shown in figure 2. In addition connect a 100 k Ω resistor from Pin 6 to Pin 7 and from Pin 6 and Pin 7 a 22 pF capacitor to ground, respectively. When an external clock is available connect it to Pin 6 leaving Pin 7 open. The external resistor of 100 k Ω is used to accelerate the start of oscillation after reset or power - on. The value depends on the "Q" of the resonator. With low Q resonators it is not necessary. The start - up time of the oscillator is between 30 μ s (with piezo resonators) and above 2 ms with high Q quartzes.

**) All Vishay Semiconductor SIR transceivers fulfill this condition

Block diagram of application circuit

Operating the interface circuit at a PC COM - port. When operating directly with an UART with 3 V - or 5 V - logic, in the application circuit no level converter is necessary.

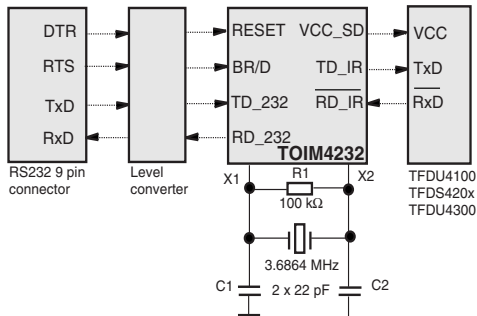

18081

Table 1.
Recommended Application Circuit Components

Component	Recommended Value	Vishay Part Number
C1	22 pF	VJ 1206 A 220 J XAMT
C2	22 pF	VJ 1206 A 220 J XAMT
R1	100 kΩ	CRCW-1206-1003-F-RT1
Quartz Crystal	3.686400 MHz	XT49S - 20 - 3.686400M

Absolute Maximum Ratings

Parameter	Test Conditions	Symbol	Min	Typ.	Max	Unit
Supply voltage		V_{CC}	- 0.5		3.6	V
Input voltage	all pins		- 0.5		5.5	V
Output voltage	all pins		- 0.5		$V_{CC} + 0.5$	V
Output sinking current, max	all pins	I_O			8	mA
Junction temperature, max		T_J			125	°C
Ambient temperature (operating)		T_{amb}	- 25		85	°C
Storage temperature		T_{stg}	- 25		85	°C
Soldering temperature	$t = 20 \text{ s @ } 215 \text{ °C}$	T_{sldr}		215	230	°C

DC Characteristics

Parameter	Test Conditions	Symbol	Min	Typ.	Max	Unit
Operating voltage		V_{CC}	2.7	3.3	3.6	V

$V_{CC} = 3.3 \text{ V} \pm 5 \%$, operating temperature = - 55 °C to + 125 °C

Parameter	Test Conditions	Symbol	Min	Typ.	Max	Unit
Input HIGH voltage	inputs tolerate levels as high as 5.5 V max. all inputs are Schmitt trigger inputs	V_{IH}		1.7	2.0	V
Input LOW voltage		V_{IL}	0.8	1.1		V
Input Schmitt trigger hysteresis		V_{hyst}		0.6		V

Parameter	Test Conditions	Symbol	Min	Typ.	Max	Unit
Input leakage no pull-up/down	$V_{IN} = V_{DD}$ or GND	I_L	- 10	± 1	10	μA
Output HIGH voltage	$I_{OH} = - 2.0$ mA	V_{OH}	2.0			V
	$I_{OH} = - 0.5$ mA	V_{OH}	2.4			V
Output LOW voltage	$I_{OL} = + 2.0$ mA	V_{OL}			0.4	V
Consumption current standby	inputs grounded, no output load $V_{CC} = 3.3$ V, $T = 25$ °C	I_{SB}			1	μA
Consumption current dynamic	inputs grounded, no output load $V_{CC} = 3.3$ V, $T = 25$ °C	I_{CC}		2		mA

Operation Description

Figure 2 shows a typical example of an RS232 port interface. The TOIM4232 connects to an RS232 level converter on one side, and an infrared transceiver on the other. The internal TOIM4232 baud rate generator can be software controlled.

When BR/D = 0, the TOIM4232 interprets the channels TD_232 to TD_IR and RD_IR to RD_232 as data channels.

On the other hand, whenever BR/D = 1, the TOIM4232 interprets TD_232 as Control Word for setting the Baud rate. The Baud rate can be programmed to operate from 1200 bit/s to 115.2 kbit/s. As RS232 level converter, EIA232 or MAX232 or equivalent are recommended.

When using the TOIM4232 directly connected to an UART it is compatible to 5 V TTL and 3.3 V CMOS logic.

Typical external resistors and capacitors are needed as shown in the TFDx4xxx references.

The output pulse duration can also be programmed, see chapter "Operation Description". It is strongly recommended using 1.627 μs output pulses to save bat-

tery power. As frequency determining component a Vishay XT49M Crystal is recommended, when no external clock is available.

We strongly recommend not to use this 3/16 mode because 3/16 pulse length at lower bit rates consumes more power than the shorter pulse. At a data rate of 9600 bit/s, the ratio of power consumption of both modes is a factor of 12 (!).

Programming the TOIM4232

For correct, data rate dependent timing the TOIM4232 is using a built-in baud rate generator. This is used when no external clock is not available as in RS232 IR-dongle applications. For programming the BR/D pin has to be set active, BR/D = 1.

In this case the TOIM4232 interprets the 7 LSBs at the TD_232 input as a Control Word. The operating baud rate will change to its supposedly new baud rate when the BR/D returns back to LOW ("0") Set the UART to 8 bit, no parity, 1 stop bit.

Control Byte (8 bit)

First Character				Second Character			
X	S2	S1	S0	B3	B2	B1	B0
							LSB

X: Do not care

S1, S2: User programmable bit to program the outputs S1 and S2

S0: Irda pulse select

S0 = (1): 1.627 μs pulses

S0 = (0): 3/16 bit time pulses, not recommended

B0 .. B3: Baud rate select words

Example:

To set TOIM4232 at COM2 port (2F8) to 9600 bit/s with 3/16 bit time pulse duration send to the TOIM4232 in programming mode in e.g. "Basic"

OUT &H2F8, (&H6)

For same port, 9600 bit/s and 1.627 μs pulse duration send

OUT &H2F8, (&H16)

For additionally activating S1 send

OUT &H2F8, (&H36)



Baud Rate Select Words

B3	B2	B1	B0	2 nd Char	Baud Rate
0	0	0	0	0	115.2 k
0	0	0	1	1	57.6 k
0	0	1	0	2	38.4 k
0	0	1	1	3	19.2 k
0	1	0	0	4	14.4 k
0	1	0	1	5	12.8 k
0	1	1	0	6	9.6 k
0	1	1	1	7	7.2 k
1	0	0	0	8	4.8 k
1	0	0	1	9	3.6 k
1	0	1	0	A	2.4 k
1	0	1	1	B	1.8 k
1	1	0	0	C	1.2 k
1	1	0	1	D	forbidden
1	1	1	0	E	forbidden
1	1	1	1	F	forbidden

Note: IrDA standard only supports 2.4, 9.6, 19.2, 57.6, and 115.2 kbit/s.

Software for the TOIM4232 UART Programming

For proper operation, the RS232 must be programmed (using 8bit, 1stop, no parity) to send a two character control word, YZ. The control word YZ is composed of two characters, written in hexadecimal, in format: YZ. The transfer rate for programming must be identical with the formerly programmed data rate, or after resetting the TOIM4232, the default rate of 9600 bit/s is used.

Step.	RESET	BR/ D	TD_UART	RD_UART	RD_IR	TD_IR	Description and Comments
1	High	X	X	X	X	X	Resets all internal registers. Resets to IrDA default data rate of 9600 bit/s
2	Low	X	X	X	X	X	Wait at least 2 ms, to allow start-up of internal clock. When external clock is used: Wait at least 7 μ s.
3	Low	High	X	X	X	X	Wait at least 7 μ s. TOIM4232 now is set to the Control Word programming mode
4	Low	High	YZ with Y = 1 for 1.627 μ s Y = 0 3/16 bit length	X	X	X	Sending the Control Word YZ. Examples: Send "1Z" if 1.627 μ s pulses are intended to be used. Otherwise send "0Z" for 3/16 bit period pulses. "Y6" keeps the 9.6 kbit/s data rate. Z = 0 sets to 115.2 kbit/s, see programming table. Wait at least 1 μ s for hold-time.
5	Low	Low	DATA	DATA	DATA	DATA	With BR/D = 0, TOIM4232 is in the data communication mode. Both RESET and BR/D must be kept LOW ("0") during data transmission. Reprogramming to a new data rate can be resumed by restarting from step 3. The UART itself also must set to the correct data rate *).

*) For programming the UART, refer to e.g., National Semiconductor's data sheet of PC 16550 UART

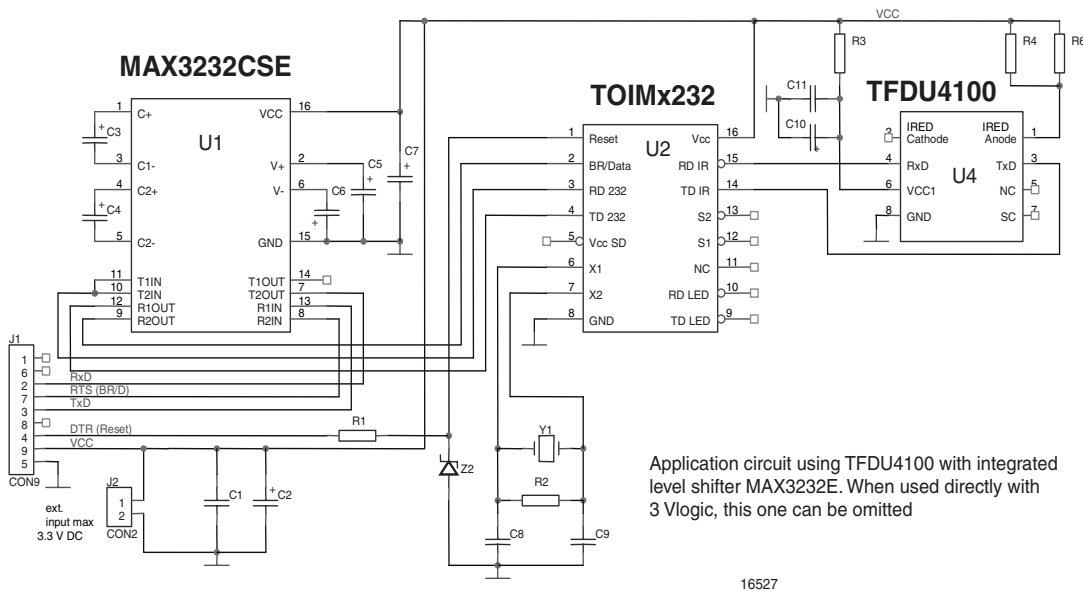

16527

Table 1.
Recommended Application Circuit Components

	Component	Recommended Value	Vishay Part Number
1	C1	100 nF	VJ 1206 Y 104 J XXMT
2	C2	10 μ F, 16 V	293D106X9016B2T
3	C3	100 nF	VJ 1206 Y 104 J XXMT
4	C4	100 nF	VJ 1206 Y 104 J XXMT
5	C5	100 nF	VJ 1206 Y 104 J XXMT
6	C6	100 nF	VJ 1206 Y 104 J XXMT
7	C7	1 μ F, 16 V	293D105X9016A2T
8	C8	22 pF	VJ 1206 A 220 J XAMT
9	C9	22 pF	VJ 1206 A 220 J XAMT
10	C10	6.8 μ F, 16 V	293D 685X9 016B 2T
11	C11	100 nF	VJ 1206 Y 104 J XXMT
12	Z2	3.6 V	BZT55C3V6
13	R1	5.6 Ω	CRCW-1206-5601-F-RT1
14	R2	100 k Ω (up to 1 M Ω , or omitted)	CRCW-1206-1003-F-RT1
15	R3	47 Ω	CRCW-1206-47R0-F-RT1
16	R4	20 Ω	CRCW-1206-20R0-F-RT1
17	R6	20 Ω	CRCW-1206-20R0-F-RT1
18	Y1	3.686400 MHz	XT49S - 20 - 3.686400M
19	U1	MAXIM MAX 3232E	
20	U2		TOIM4232
21	U3		TFDU4100
22	J1	9 Pin - D - Sub	Cannon
23	J2	Power connector	
24	PCB		VISHAY Dongle_4

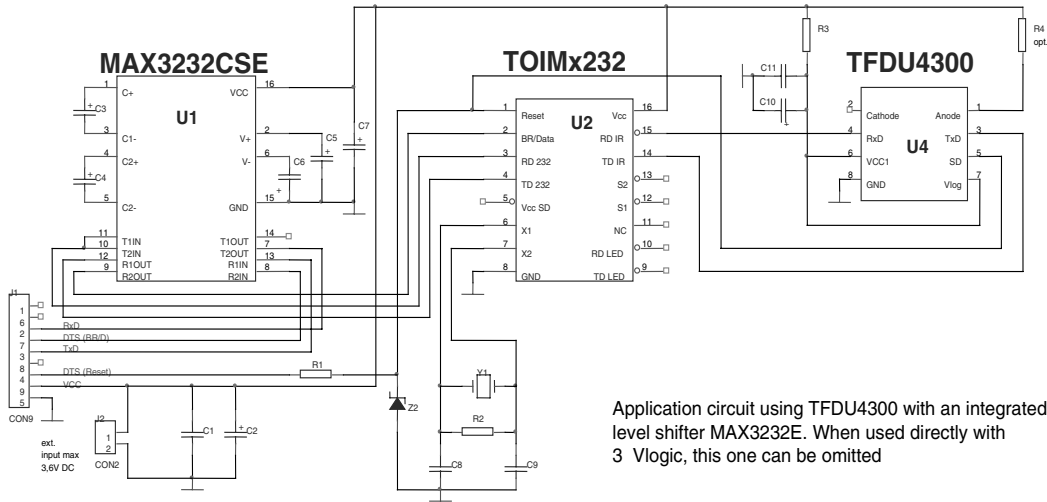

Application circuit using TFDU4300 with an integrated level shifter MAX3232E. When used directly with 3 Vlogic, this one can be omitted

18240

Table 2.
Recommended Application Circuit Components

	Component	Recommended Value	Vishay Part Number
1	C1	100 nF	VJ 1206 Y 104 J XXMT
2	C2	10 μF, 16 V	293D106X9016B2T
3	C3	100 nF	VJ 1206 Y 104 J XXMT
4	C4	100 nF	VJ 1206 Y 104 J XXMT
5	C5	100 nF	VJ 1206 Y 104 J XXMT
6	C6	100 nF	VJ 1206 Y 104 J XXMT
7	C7	1 μF, 16 V	293D105X9016A2T
8	C8	22 pF	VJ 1206 A 220 J XAMT
9	C9	22 pF	VJ 1206 A 220 J XAMT
10	C10	6.8 μF, 16 V	293D 685X9 016B 2T
11	C11	100 nF	VJ 1206 Y 104 J XXMT
12	Z2	3.6 V	BZT55C3V6
13	R1	5.6 kΩ	CRCW-1206-5601-F-RT1
14	R2	100 kΩ (up to 1 MΩ, or omitted)	CRCW-1206-1003-F-RT1
15	R3	47 Ω	CRCW-1206-47R0-F-RT1
16	R4	20 Ω	CRCW-1206-20R0-F-RT1
17	Y1	3.686400 MHz	XT49S - 20 - 3.686400M
18	U1	MAXIM MAX 3232E	
19	U2		TOIM4232
20	U3		TFDU4300
21	J1	9 Pin - D-Sub	Cannon
22	J2	Power connector	
23	PCB		VISHAY Dongle_4

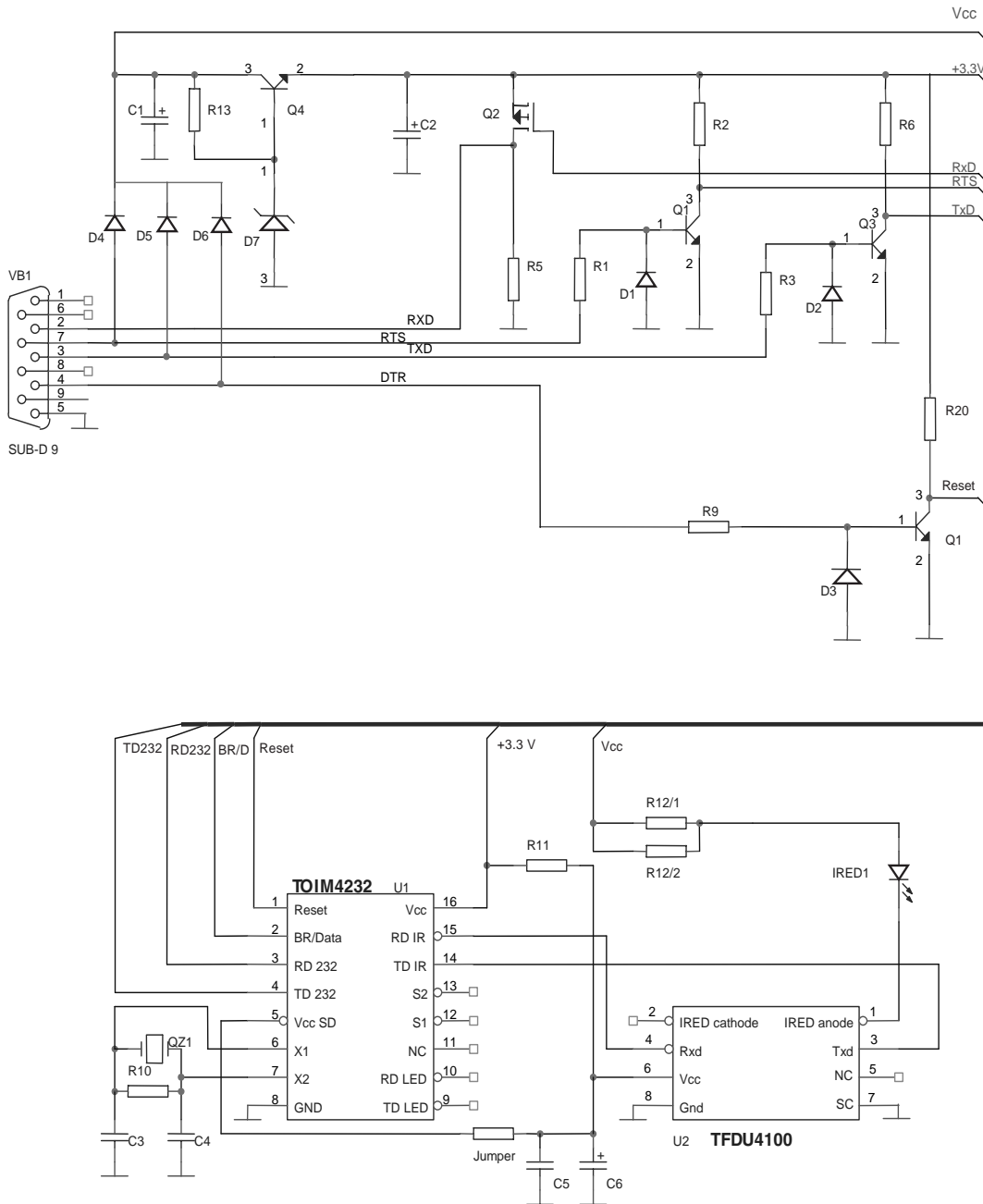

18082

Install Jumper connection only when V_{CC} SD supplies U2. In that case leave R11 off.

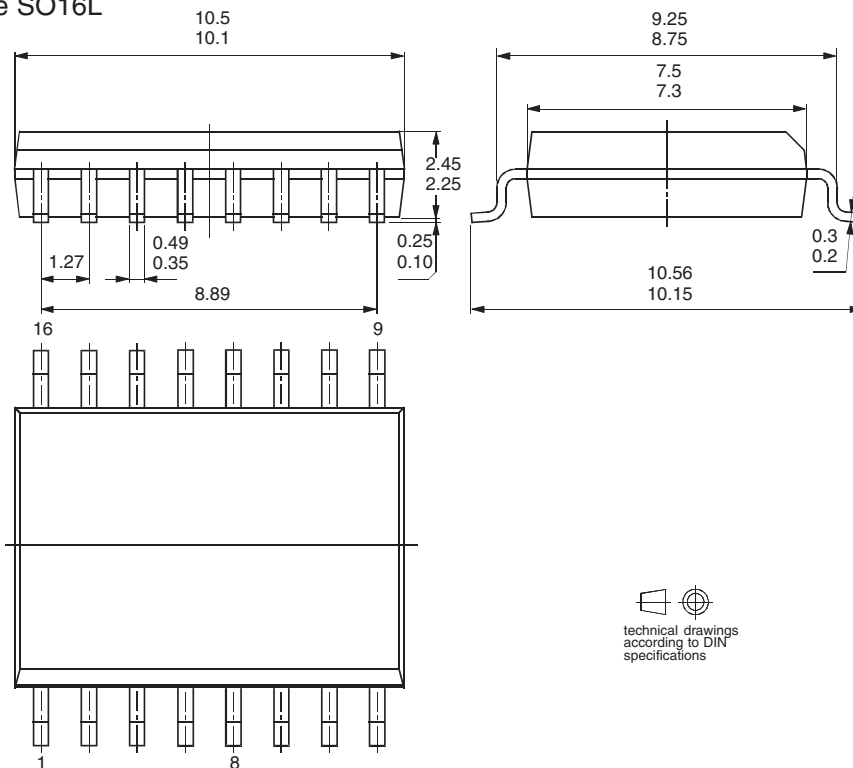

Table 3.
Recommended Application Circuit Components

	Component	Recommended Value	Vishay Part Number
1	C1	22 μ F, 16 V	293D 226X9 016C 2T
2	C2	47 μ F, 16 V	293D 476X9 016D 2T
3	C3	22 pF	VJ 1206 A 220 J XAMT
4	C4	22 pF	VJ 1206 A 220 J XAMT
5	C5	100 nF	VJ 1206 Y 104 J XXMT
6	C6	6.8 μ F, 16 V	293D 685X9 016B 2T
7	D1		1N4148
8	D2		1N4148
9	D4		BZT55C4V7
10	D5		1N4148
11	D6		1N4145
12	D7		BZT55C3V9
13	IREd1		TSHF5400
14	Jumper		CRCW-1206-000-F-RT1
15	LED1		TLLY4401
16	LED2		TLLG4401
17	Q1		BC817-25
18	Q2		VP 0610 0T
19	Q3		BC817-25
20	Q4		BC817-25
21	QZ1	3.686400 MHz	XT49S - 20 - 3.686400M
22	R1	22 k Ω	CRCW-1206-2202-F-RT1
23	R2	10 k Ω	CRCW-1206-1002-F-RT1
24	R3	22 k Ω	CRCW-1206-2202-F-RT1
25	R5	1 k Ω	CRCW-1206-1001-F-RT1
26	R6	47 k Ω	CRCW-1206-4702-F-RT1
27	R9	5.6 k Ω	CRCW-1206-5601-F-RT1
28	R10	100 k Ω	CRCW-1206-1003-F-RT1
29	R11	100 Ω	CRCW-1206-1000-F-RT1
30	R12	20 Ω	CRCW-1206-20R0-F-RT1
21	R13	1 k Ω	CRCW-1206-1001-F-RT1
32	R17	750 Ω	CRCW-1206-7500-F-RT1
33	R18	750 Ω	CRCW-1206-750-F-RT1
34	VB1	9 Pin - D- Sub	Cannon
35	PCB		VISHAY Dongle_3
36	U1		TOIM4232
37	U2		TFDU4100

Package Dimensions in mm

Package SO16L



technical drawings
according to DIN
specifications

13011

Reel Dimensions

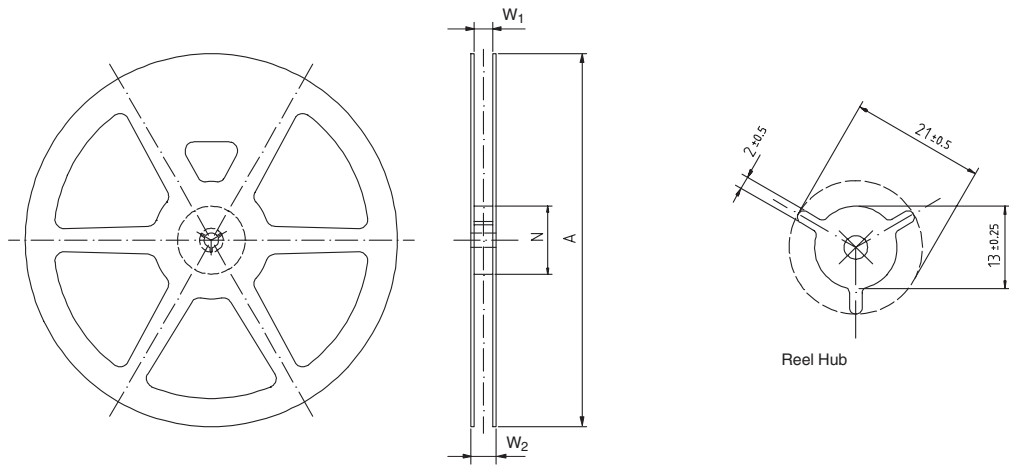

14017

Tape Width	A max.	N	W_1 min.	W_2 max.	W_3 min.	W_3 max.
mm	mm	mm	mm	mm	mm	mm
16	330	50	16.4	22.4	15.9	19.4

Tape Dimensions in mm

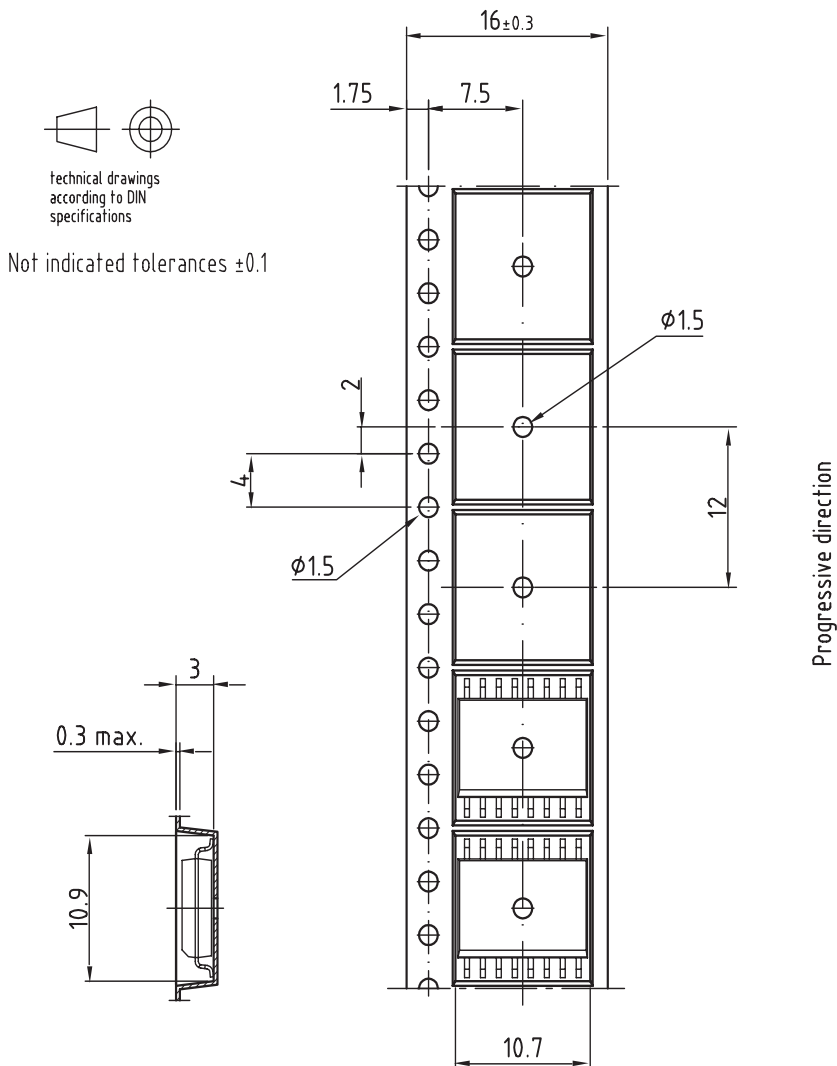

Drawing refers to following types: TOIM 4232

Drawing-No.: 9.700-5284.01-4

Issue: 1; 24.07.03

18241

Ozone Depleting Substances Policy Statement

It is the policy of **Vishay Semiconductor GmbH** to

1. Meet all present and future national and international statutory requirements.
2. Regularly and continuously improve the performance of our products, processes, distribution and operating systems with respect to their impact on the health and safety of our employees and the public, as well as their impact on the environment.

It is particular concern to control or eliminate releases of those substances into the atmosphere which are known as ozone depleting substances (ODSs).

The Montreal Protocol (1987) and its London Amendments (1990) intend to severely restrict the use of ODSs and forbid their use within the next ten years. Various national and international initiatives are pressing for an earlier ban on these substances.

Vishay Semiconductor GmbH has been able to use its policy of continuous improvements to eliminate the use of ODSs listed in the following documents.

1. Annex A, B and list of transitional substances of the Montreal Protocol and the London Amendments respectively
2. Class I and II ozone depleting substances in the Clean Air Act Amendments of 1990 by the Environmental Protection Agency (EPA) in the USA
3. Council Decision 88/540/EEC and 91/690/EEC Annex A, B and C (transitional substances) respectively.

Vishay Semiconductor GmbH can certify that our semiconductors are not manufactured with ozone depleting substances and do not contain such substances.

**We reserve the right to make changes to improve technical design
and may do so without further notice.**

Parameters can vary in different applications. All operating parameters must be validated for each customer application by the customer. Should the buyer use Vishay Semiconductors products for any unintended or unauthorized application, the buyer shall indemnify Vishay Semiconductors against all claims, costs, damages, and expenses, arising out of, directly or indirectly, any claim of personal damage, injury or death associated with such unintended or unauthorized use.

Vishay Semiconductor GmbH, P.O.B. 3535, D-74025 Heilbronn, Germany
Telephone: 49 (0)7131 67 2831, Fax number: 49 (0)7131 67 2423