

Spec. No.	ICR18650-26J	Version No.	Tentative v0.1
-----------	--------------	-------------	----------------

SPECIFICATION OF PRODUCT

**for Lithium-ion rechargeable cell
Model name : ICR18650-26J (Version 3)**

01 Jul 2020

**Samsung SDI Co., Ltd.
Battery Business Division**



Spec. No.	ICR18650-26J	Version No.	Tentative v0.1
-----------	--------------	-------------	----------------

Revision history

Revision No.	Date(‘yr-m-d)	Page	Item	Description	Changes / Author
Tentative	‘20-04-14			Tentative specification	Kim Sol
Tentative v0.1	‘20-07-01			Tentative release	Lucy Kim

Spec. No.	ICR18650-26J	Version No.	Tentative v0.1
-----------	--------------	-------------	----------------

1. Scope

This product specification has been prepared to specify the rechargeable lithium-ion cell ("Cell" or "Cells") to be supplied to the customer by Samsung SDI Co., Ltd. ("Samsung SDI")

2. Description and Model

2.1 Description	Cell (lithium-ion rechargeable cell)
2.2 Model	ICR18650-26J (Version 3)
2.3 Site	Manufactured in Korea, Malaysia & China

3. Nominal specifications (*1)

Item	Specification
3.1 Standard discharge capacity	Min 2,550mAh - Charge : 0.5C (1300mA), 4.2V 20mA or 3hr cut-off @RT - Discharge : 0.2C (520mA), 2.75V cut-off @RT *1C=2,600mA (Typical Capacity 2,600mAh)
3.2 Charging Voltage	4.2V
3.3 Nominal Voltage	3.63V
3.4 Charging Method	CC-CV (constant voltage with limited current)
3.5 Charging Current	Standard charge: 1,300mA
3.6 Charging Time	Standard charge: 3hours
3.7 Max. Charge Current	2,600mA (not for cycle life)
3.8 Max. Discharge Current	10A (Continuous discharge @RT)
3.9 Discharge Cut-off Voltage	2.75V (End of discharge)
3.10 Cycle life	Capacity \geq 1,785mAh @ after 500cycles (70% of the Standard Discharge Capacity @ RT) - Charge : 0.5C (1.3A), 4.20V, 130mA or 3hr cut-off @ RT - Discharge : 1C (2.6A), 2.75V cut-off @ RT
3.11 Storage characteristics	Capacity recovery(after the storage) \geq 2,040mAh (80% of the Standard capacity @ RT) - Charge : 0.5C(1,300mA), 4.2V 20mA or 3hr cut-off @ RT - Storage : 30 days (@ RT) - Discharge : 0.2C(520mA), 2.75V cut-off @ RT
3.12 Cell Weight	46g max
3.13 Cell Dimension	Height : Max. 65.0 mm Diameter : Max.18.4 mm



Spec. No.	ICR18650-26J	Version No.	Tentative v0.1
-----------	--------------	-------------	----------------

3.14 Operating Temperature (*2)	Charge : 0 to 45°C (Ambient) Discharge : -20 to 60°C (Ambient)
3.15 Recovery 80% after storage(*3)	1 year : -20~23°C 3 months : -20~45°C 1 month : -20~60°C

Note (*1): Protection function of the battery pack should be set within the specified charge, discharge and temperature range in Cell Specification.

Note (*2): Discharge OTP(over temp. protection) should not be over 70°C of Cell surface temperature. Protection set should be based on the location of Cell surface with the highest temp increase part of the battery pack.

Note (*3): If Cell is kept as ex-factory status (30% of charge), the capacity recovery rate shall be more than 80%.

Spec. No.	ICR18650-26J	Version No.	Tentative v0.1
-----------	--------------	-------------	----------------

4. Outline Dimensions

See the Fig. 1

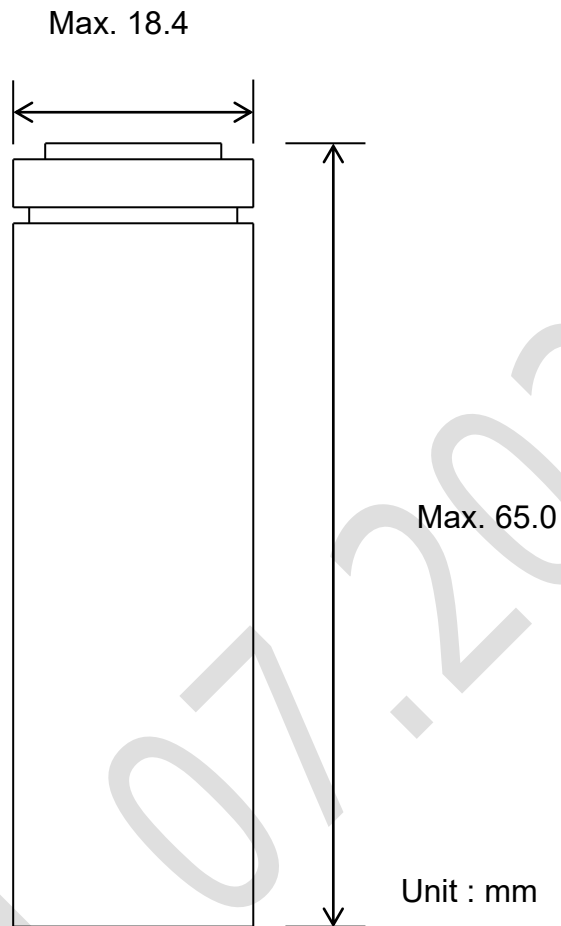

Fig. 1 Outline Dimensions of ICR18650-26J

Spec. No.	ICR18650-26J	Version No.	Tentative v0.1
-----------	--------------	-------------	----------------

5. Appearance

There shall be no such defects as scratch, rust, discoloration, leakage which may adversely affect commercial value of Cell.

6. Standard Test Conditions

6.1 Environmental Conditions

Unless otherwise specified, all tests stated in this specification are conducted at temperature $23\pm 3^{\circ}\text{C}$ (@RT) and humidity under 65%.

6.2 Measuring Equipment

(1) Amp-meter and Volt-meter

The amp-meter and volt-meter should have an accuracy of the grade 0.5mA and mV or higher.

(2) Slide caliper

The slide caliper should have 0.01 mm scale.

(3) Impedance meter

The impedance meter with AC 1kHz should be used.

7. Characteristics

7.1 Standard Charge

This "Standard Charge" means charging Cell with charge current of $0.5C$ (1,300mA) and constant voltage 4.2V and 20mA or 3hr cut-off in CV mode at 23°C for capacity.

7.2 Standard Discharge Capacity

The standard discharge capacity is the initial discharge capacity of Cell, which is measured with discharge current of $0.2C$ (520mA) with 2.75V cut-off at 23°C within 1 hour after the Standard charge.

$$\text{Standard Discharge Capacity} \geq 2,550\text{mAh}$$

7.3 Initial internal impedance

Initial internal impedance measured at AC 1kHz after Standard charge.

$$\text{Initial internal impedance} \leq 35\text{m}\Omega$$

Spec. No.	ICR18650-26J	Version No.	Tentative v0.1
-----------	--------------	-------------	----------------

7.4 Temperature Dependence of Discharge Capacity

Discharge capacity comparison at each temperature, measured with discharge constant current 1.0C(2,600mA) and 2.75V cut-off with follow temperature after the Standard charging at 23°C.

Charge Temperature	Discharge temperature			
	-10°C	0°C	23°C	40°C
23°C				
Relative Capacity	60%	70%	90%	95%

Note: If charge temperature and discharge temperature is not the same, the interval for temperature change is 3 hours.

Percentage as an index of the Standard discharge capacity (=2,550mAh) is 100%.

7.5 Discharge Rate Capabilities

Discharge capacity is measured with the various currents in under table and 2.75V cut-off after the Standard charge at 23°C.

Current	Discharge Condition			
	0.2C (520mA)	1C (2,600mA)	2C (5,200mA)	3.85C (10,000 mA)
Relative Capacity	100%	90%	80%	70%

Note: Percentage as an index of the Standard discharge capacity (=2,550mAh) is 100%.

7.6 Cycle Life

Each cycle is an interval between the charge (charge current 1,300mA) with 0.05C(130mA) or 3 hr cut-off and the discharge (discharge current 2,600mA) with 2.75V cut-off. Capacity after 500cycles, measured under the same condition in 7.2

Capacity \geq 1,785mAh (70% of Standard Discharge Capacity)

7.7 Recovery Characteristics

Capacity after storage for 30days at 23°C after the Standard charged at 23°C, measured with discharge current 0.2C(520mA) with 2.75V cut-off at 23°C.

Capacity recovery(after the storage) \geq 2,040mAh (80% of Standard Capacity at 23°C)

7.8 Status of Cell as of ex-factory

Cell should be shipped in 3.55V ~ 3.63V Charging voltage range.

Spec. No.	ICR18650-26J	Version No.	Tentative v0.1
-----------	--------------	-------------	----------------

8. Mechanical Characteristics

8.1 Drop test

Test method: Fully standard charged Cells drop onto the concrete floor from 1.0m height at a random direction 3 times. Cell or batteries are dropped so as to obtain impacts in random orientations. After the test, the sample shall be put on rest for a minimum of one hour and then a visual inspection shall be performed.

Criteria: No fire, no explosion.

Drop test shall be performed with the IEC62133 standard

8.2 Vibration test

Test method: As to the UN transportation regulation (UN38.3), for each axis (X and Y axis with cylindrical Cells) 7Hz→200Hz→7Hz for 15min, repetition 12 times totally 3hours, the acceleration 1g during 7 to 18Hz and 8g (amplitude 1.6mm) up to 200Hz.

Criteria: No leakage, with less than 10% of OCV drop

Vibration test shall be performed with the UN38.3 standard

9. Safety

9.1 Overcharge Test

Test method: Cell is to be discharged at a constant current of 0.52A to 2.75V. Cell is then to be charged with a 12V and 3C (7.8A). Charging duration is to be 7 h.

Criteria: No fire, and no explosion.

Overcharge test shall be performed with the UL1642 standard

9.2 External short-circuit test

Test method: Fully Standard charged Cell is to be short-circuited by connecting the positive and negative terminals of the battery with a circuit load having a resistance load of $80 \pm 20 \text{ m}\Omega$. The battery is to discharge until a fire or explosion is obtained, or until it has reached a completely discharged state of less than 0.2 V and the battery case temperature has returned to $\pm 10^\circ\text{C}$ of ambient temperature. The return to near ambient of the battery (Cell) casing in an indication of ultimate results. Tests are to be conducted at $20 \pm 5^\circ\text{C}$ and at $55 \pm 5^\circ\text{C}$.

Criteria: No fire, and no explosion.

External short-circuit test shall be performed with the UL1642 standard

Spec. No.	ICR18650-26J	Version No.	Tentative v0.1
-----------	--------------	-------------	----------------

9.3 Forced discharge test

Test method: A discharged Cell is subjected to a reverse charge at 1.0C (2,600mA) for 90 min.

Criteria: No fire, and no explosion.

Forced discharge test shall be performed with the IEC62133 standard

9.4 Heating test

Test method: To heat up the standard charged Cell at heating rate 5°C per minute up to 130°C and keep Cell in oven for 30 min..

Criteria: No fire, and no explosion.

Heating test shall be performed with the UL1642 standard (10 min) & GB31241 standard (30 min).

9.5 Impact test

Test method: To place 15.8mm diameter bar across the center of standard charged Cell, and drop 9.1kg weight from 61cm height onto Cell.

Criteria: No fire, and no explosion.

Impact test shall be performed with the UL1642 standard & UN38.3 standard.

10. Warranty

Samsung SDI warrants that Cell will be free from defects in manufacturing for a period of 15 months from the date of shipping ("Warranty Period"). In case of defects, Samsung SDI will only replace the affected Cell. However, Samsung SDI shall not be liable for if (i) Cell was improperly installed, repaired, altered or otherwise modified (other than by Samsung SDI), (ii) Cell was subjected to misuse, abuse, negligence or accident, or (iii) Cell was used, handled, stored, sold or distributed in a manner contrary or inconsistent to the handling /use instructions provided in this product specification sheet and the customer environment test guidelines (if any).

11. Others

11.1 Storage for a long time

If Cell is kept for a long time (3months or more), It is strongly recommended that the cell is preserved at dry and low-temperature.

11.2 Other

Any matters that specifications does not have, should be conferred with between the both parties.

Spec. No.	ICR18650-26J	Version No.	Tentative v0.1
-----------	--------------	-------------	----------------

12. Packaging

12.1 Ocean

NO	PART NAME	MATERIAL	Q'ty	NO	PART NAME	MATERIAL	Q'ty
1	PACKING GUIDE	MANILA 300g	2 pcs /BOX	9	Ship.Lot LABEL	ART PAPER	1 pcs /PALLET
				10	PAL LABEL	ART PAPER	1 pcs /PALLET
2	CELL	CILINDERICAL	200 pcs /BOX	11	PALLET	PLASTIC	1 pcs /PALLET
3	BOX(PACKING CASE IN)	SW1-E	2 pcs /BOX	12	CORNER BLOCK	C.F.B	8 pcs /PALLET
4	BOX(PACKING CASE OUT)	DW1-BA	1 pcs /BOX	13	PALLET VINYL	LD-PE	1 pcs /PALLET
5	BAG PE	LD-PE	1 pcs /BOX	14	WRAP STRETCH	LD-PE	0.044 ROL/PALLET
6	SILICAGEL	SI	2 pcs /BOX	15	BAND (BAND PP)	PP	0.016 ROL/PALLET
7	TAPE	OPP	0.02ROL/BOX	16	Stack LABEL	ART PAPER	1 pcs /PALLET
8	Product LABEL	ART PAPER	1 pcs/BOX	17	Inspection LABEL	ART PAPER	1 pcs /PALLET

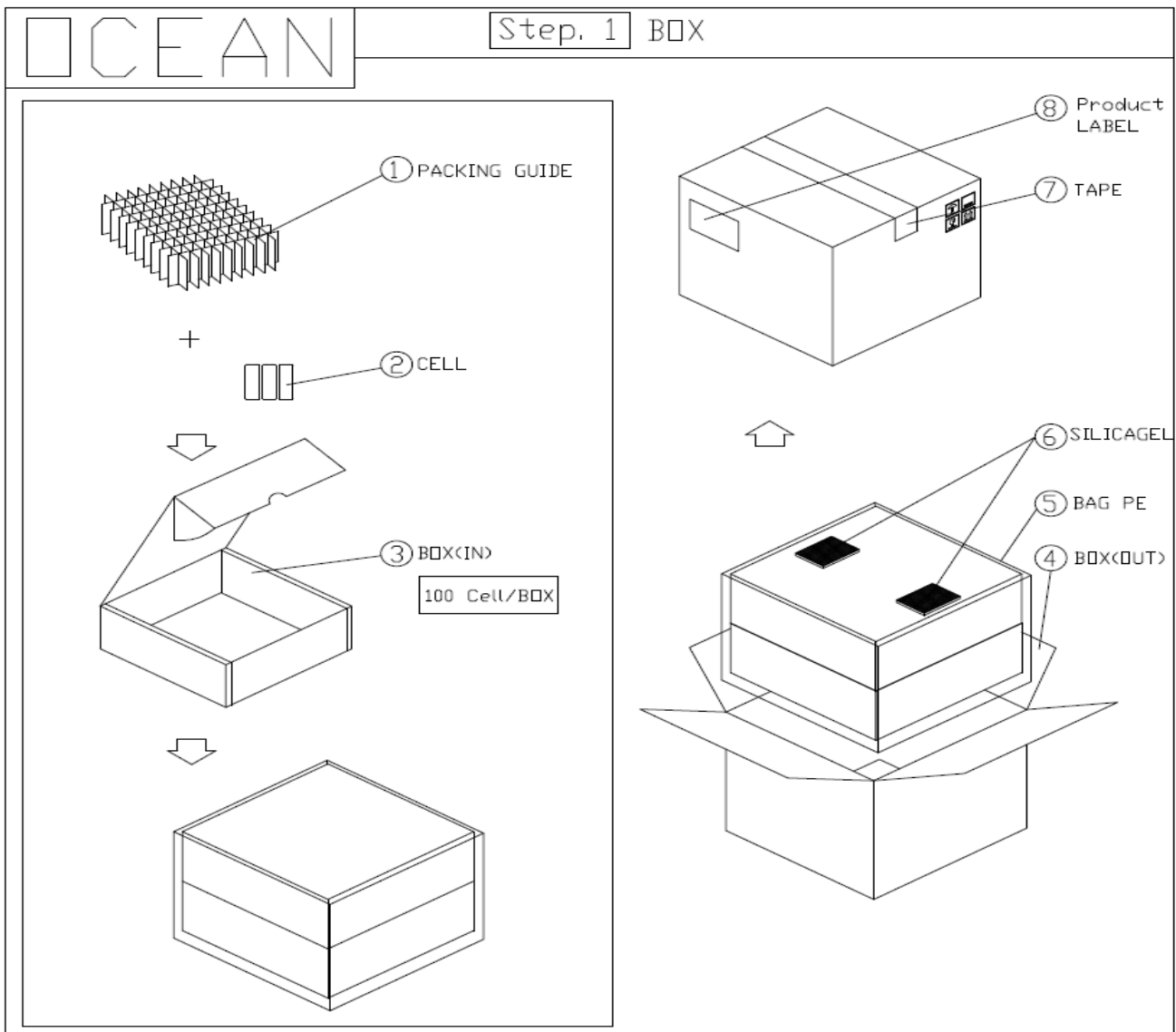

Spec. No.	ICR18650-26J	Version No.	Tentative v0.1
-----------	--------------	-------------	----------------

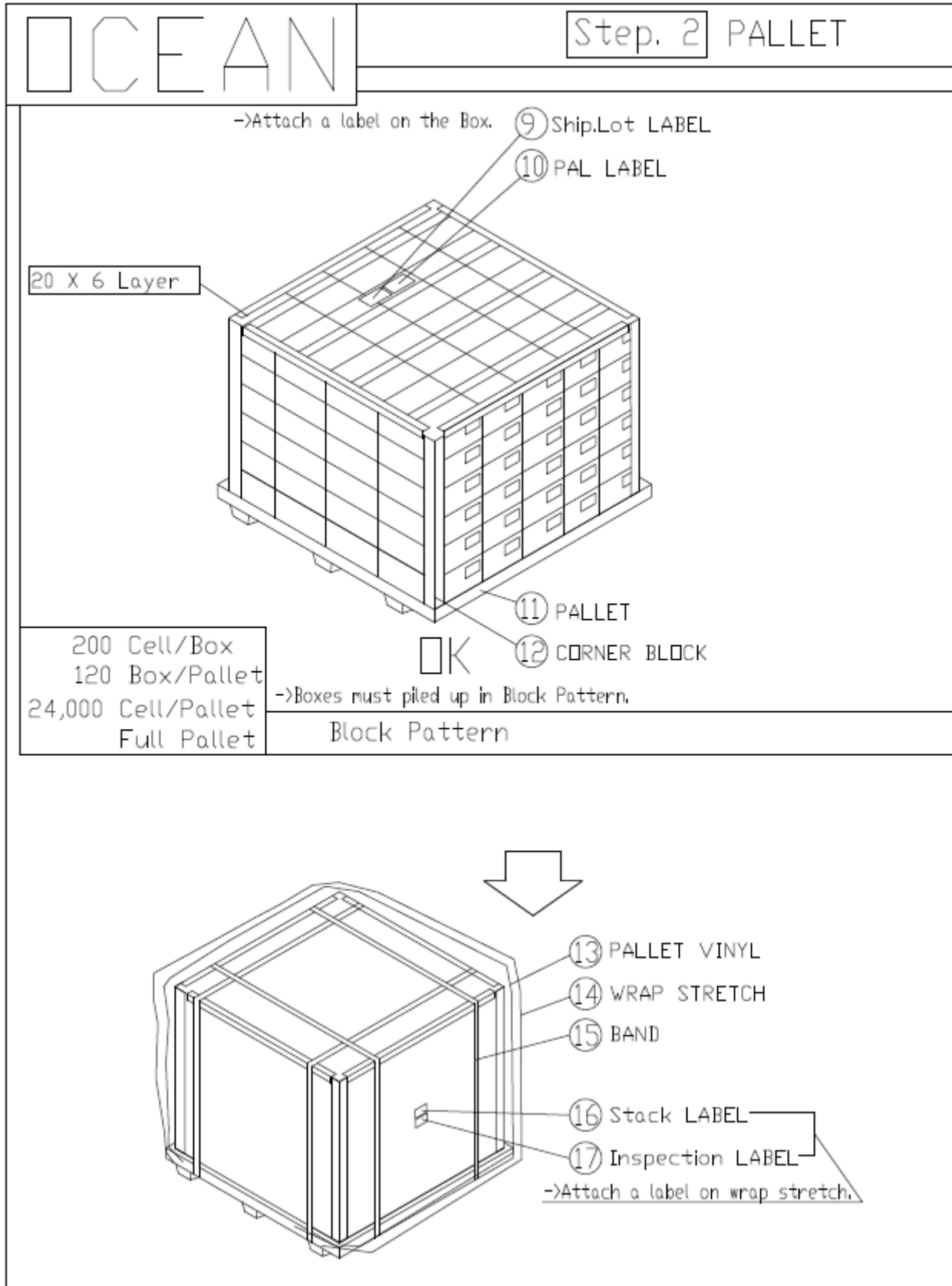

Spec. No.	ICR18650-26J	Version No.	Tentative v0.1
-----------	--------------	-------------	----------------

12.2 Air

NO	PART NAME	MATERIAL	Q'ty	NO	PART NAME	MATERIAL	Q'ty
1	PACKING GUIDE	MANILA 300g	2 pcs /BOX	11	CLASS9+Adress LABEL	ART PAPER	1 pcs /BOX
2	CELL	CILINDERICAL	200 pcs /BOX	12	Ship.Lot LABEL	ART PAPER	1 pcs /PALLET
3	BOX(PACKING CASE IN)	SW1-E	2 pcs /BOX	13	PAL LABEL	ART PAPER	1 pcs /PALLET
4	BOX(PACKING CASE OUT)	DW1-BA	1 pcs /BOX	14	PALLET	PLASTIC	1 pcs/PALLET
5	BAG PE	LD-PE	1 pcs /BOX	15	CORNER BLOCK	C.F.B	8 pcs/PALLET
6	SILICAGEL	SI	2 pcs /BOX	16	PALLET VINYL	LD-PE	1 pcs /PALLET
7	Product LABEL	OPP	0.02ROL/BOX	17	WRAP STRETCH	LD-PE	0.044 ROL/PALLET
8	TAPE	ART PAPER	1 pcs /BOX	18	BAND (BAND PP)	PP	0.016 ROL/PALLET
9	CAD LABEL	ART PAPER	1 pcs /BOX	19	Stack LABEL	ART PAPER	1 pcs /PALLET
10	ICAD LABEL	ART PAPER	1 pcs /BOX	20	Inspection LABEL	ART PAPER	1 pcs /PALLET

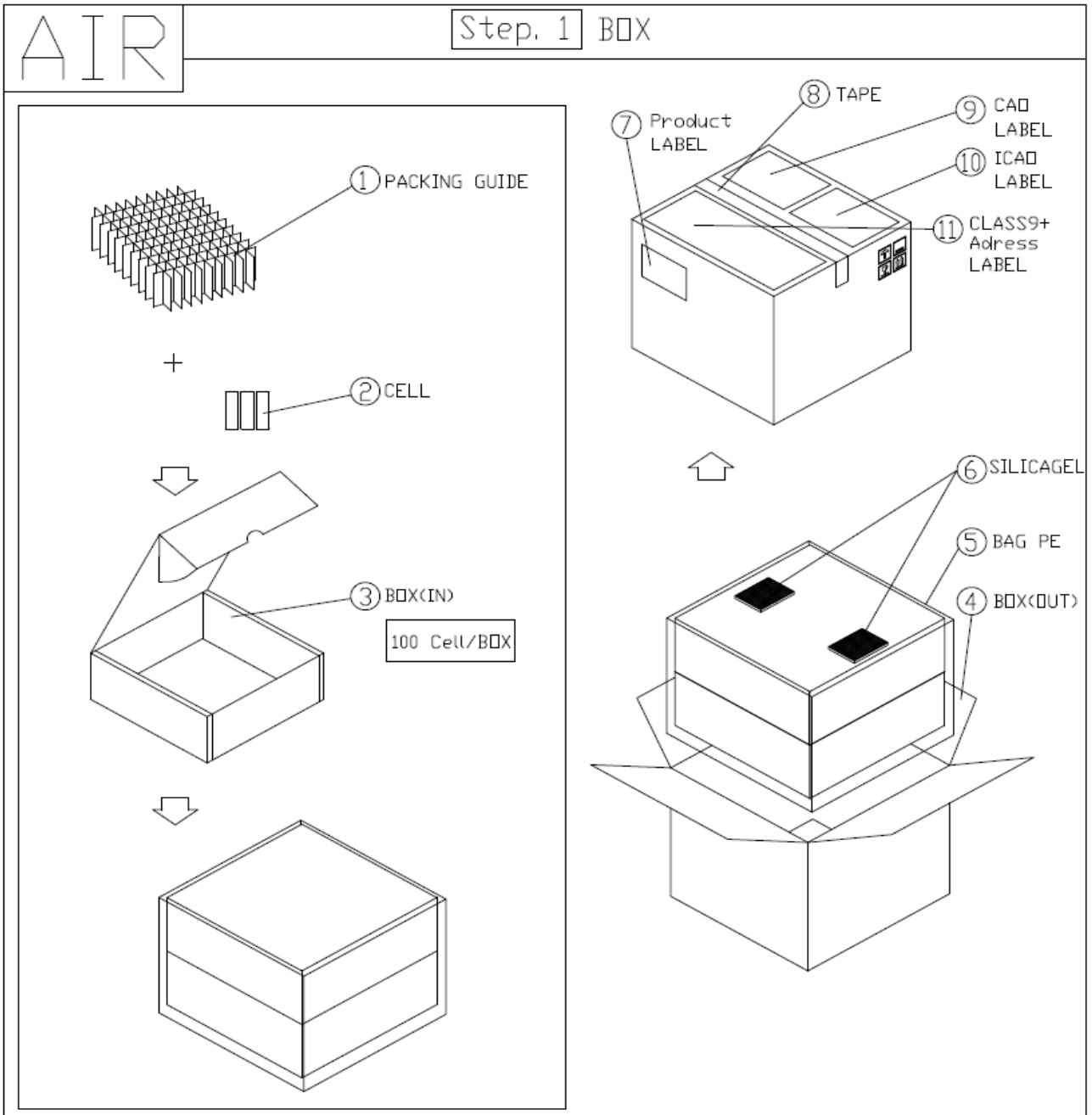

Spec. No.	ICR18650-26J	Version No.	Tentative v0.1
-----------	--------------	-------------	----------------

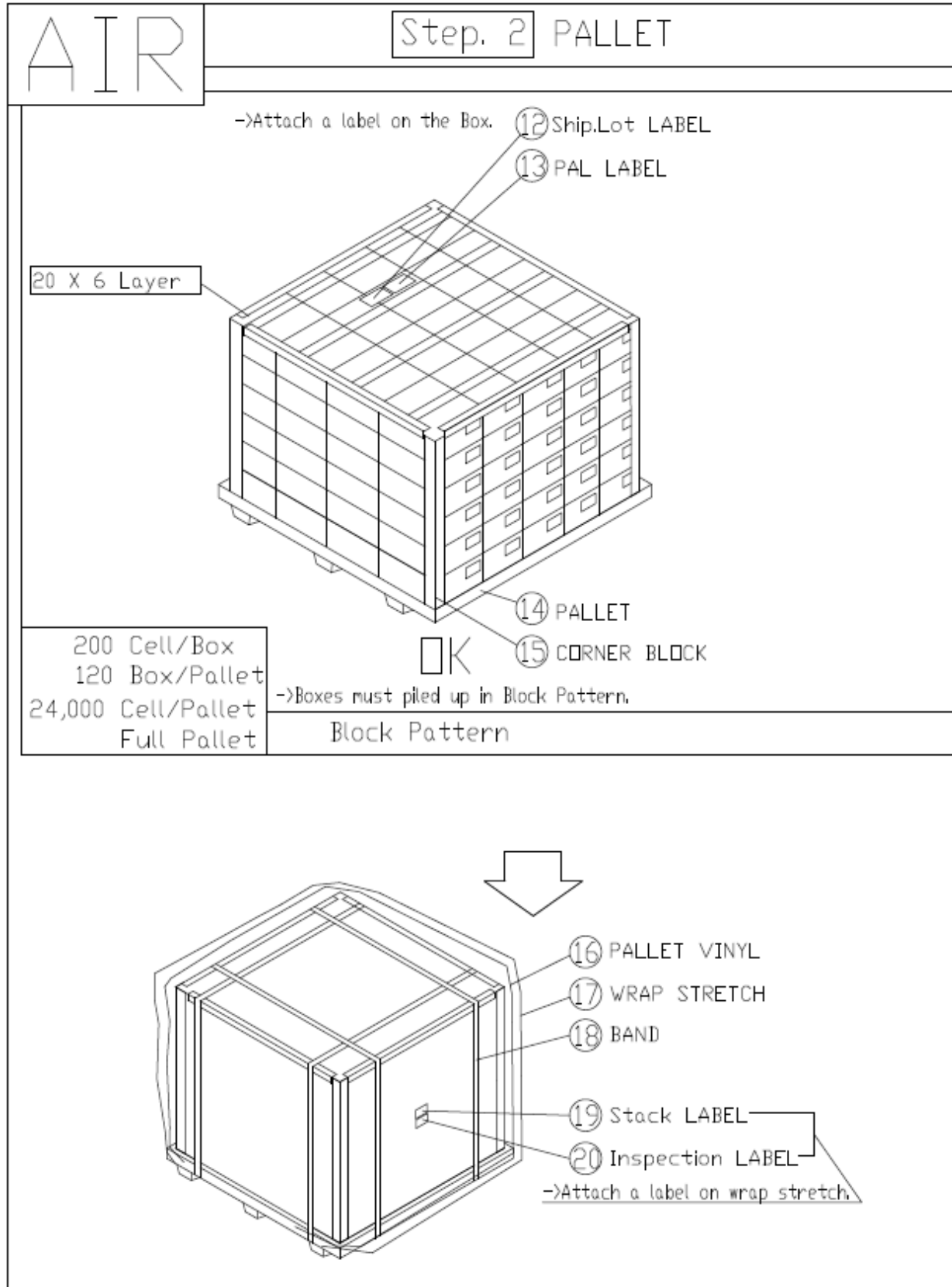

Spec. No.	ICR18650-26J	Version No.	Tentative v0.1
-----------	--------------	-------------	----------------

Proper Use and Handling of Lithium Ion Cells

See before using lithium-ion cell

This document has been prepared to describe the appropriate cautions and prohibitions, which the customer should take or employ when the customer uses and handles the lithium ion cell to be manufactured and supplied by Samsung SDI in order to obtain optimum performance and safety.

1. Charging

1.1 Charging current

Charging current should be less than maximum charge current specified in the product specification.

1.2 Charging voltage

Charging should be done by voltage less than that specified in the product specification.

1.3 Charging time

Continuous charging under specified voltage does not cause any loss of performance characteristics. However, the charge timer is recommended to be installed from a safety consideration, which shuts off further charging at time specified in the product specification.

1.4 Charging temperature

Cell should be charged within a range of specified temperatures in the specification.

1.5 Reverse charging

Cell should be connected, confirming that its poles are correctly aligned. Inverse charging should be strictly prohibited. If Cell is connected improperly, it may be damaged.

2. Discharging

2.1 Discharging

Cell shall be discharged continuously at less than maximum discharge current specified in the product specification. In case of the higher discharge current should be set, it shall be discussed together with SDI.

2.2 Discharging temperature

2.2.1 Cell should be discharged within a range of temperatures specified in the product specification.

2.2.2 Otherwise, it may cause loss of characteristics.

Spec. No.	ICR18650-26J	Version No.	Tentative v0.1
-----------	--------------	-------------	----------------

2.3 Over-discharging

- 2.3.1 The system should be equipped with a device to prevent further discharging exceeding discharging cut-off voltage specified in the product specification.
- 2.3.2 Over-discharging may cause loss of performance, characteristics of battery function.
- 2.3.3 Over-discharging may occur by self-discharge if the battery is left for a very long time without any use.
- 2.3.4 The charger should be equipped with a device to detect Cell voltage and to determine recharging procedures.

3. Storage

3.1 Storage conditions

- 3.1.1 Cell should be stored within a range of temperatures specified as below*⁴
*⁴ Store the battery at 0 ~ 23°C, low humidity (below 65%), no dust and no corrosive gas atmosphere
- 3.1.2 Otherwise, it may cause loss of performance characteristics, leakage and/or rust.

3.2 Long-term storage

- 3.2.1 Cell should be used within a short period because long-term storage may cause loss of capacity by self-discharging.
- 3.2.2. If long-term (but not longer than Warranty Period as set forth in Section 10 (Warranty)) storage is necessary, Cell shall be stored at shipping voltage, because storage with higher voltage may cause more loss of performance characteristics.

3.3 Storage period

Samsung SDI shall not be liable for any defects of Cell after Warranty Period even if Cell is stored in accordance with Sections 3.1 and 3.2 above.

4. Cycle life

4.1 Cycle life performance

- 4.1.1 Cell can be charged/discharged repeatedly up to times specified in the produce specification with a certain level of capacity also specified in the product specification.
- 4.1.2 Cycle life may be determined by conditions of charging, discharging, operating temperature and/or storage.

5. Battery Pack Assembly

5.1 Prohibition of usage of damaged Cell

- 5.1.1 Cell should be inspected visually before battery assembly.
- 5.1.2 Cell should not be used if sleeve-damage, can-distortion and/or electrolyte-smell is detected.

5.2 Terminals handling

Spec. No.	ICR18650-26J	Version No.	Tentative v0.1
-----------	--------------	-------------	----------------

5.2.1 Excessive force on the negative terminal should be avoided when external strip terminal is welded.

5.3 Transportation

5.3.1 If Cell is necessary to be transported to such as the battery manufacturer, careful precautions should be taken to avoid damage of Cell.

6. Others

6.1 Disassembly

6.1.1 Cell should not be dismantled from the battery pack.

6.1.2 Internal short-circuit caused by disassembly may lead to heat generation and/or venting.

6.1.3 When the electrolyte is coming in contact with the skin or eyes, wash immediately with fresh water and seek medical advice.

6.2 Short-circuiting

6.2.1 Short-circuit results in very high current which leads to heat generation.

6.2.2 An appropriate circuitry should be employed to protect accidental short-circuiting.

6.3 Incineration

6.3.1 Incinerating and disposing of Cell in fire are strictly prohibited, because it may cause rupture and explosion.

6.4 Immersion

6.4.1 Soaking Cell in water is strictly prohibited, because it may cause corrosion and leakage of components to be damaged to functions.

6.5 Mixing use

6.5.1 Different types of Cell, or same types but different Cell manufacturer's shall not be used, which may lead to Cell imbalance, Cell rupture or damage to system due to the different characteristics of Cell.

6.5.2 Do not mix use Cells from different batches/ranks even they are the same Cell types from the same manufacturer.

6.6 Battery disposal

6.6.1 Although Cell contains no environmentally hazardous component, such as lead or cadmium. the battery should be disposed according to the local regulations when it is disposed.

6.6.2 Cell should be disposed with a discharged state to avoid heat generation by an inadvertent short-circuit.

6.7 Caution

6.7.1 The Battery used in this device may present a risk of fire or chemical burn if mistreated.

6.7.2 Do not disassemble, expose to heat above 100 °C or incinerate it.

6.7.3 Replace battery with Samsung SDI battery only.

Spec. No.	ICR18650-26J	Version No.	Tentative v0.1
-----------	--------------	-------------	----------------

6.7.4 Use of another battery may present a risk of fire or explosion.

6.7.5 Dispose of used battery promptly.

6.7.6 Keep away from children.

6.7.7 Do not disassemble and do not dispose of in fire.

Pack Design Guideline for Lithium Ion Cells

If a customer's battery pack cannot meet Pack Design Guideline below, SDI shall not be responsible for any quality issues arising out of or in connection with Cell.

1. Electrical design

1.1 Charge

1.1.1 Stop charging the battery if charging isn't completed within the specified time.

1.1.2 The battery can be used within the following temperature ranges.

Don't exceed these ranges.

Charge temperature ranges : 0°C ~ 45°C (Ambient).

1.1.3 Charge current must be controlled by specified value in Cell specification.

1.1.4 Cut-off Voltage of charging must be 4.2V.

1.1.5 Charger must stop charging battery by detecting either charging time or current specified in Cell specification.

1.1.6 Recharge Voltage must be at least 0.1V lower than Max charging Voltage.

1.1.7 Do not charge the battery under 1.0V voltage.

1.1.8 Voltage range of the battery for pre-charge mode is 1.0 ~ 3.0V with a charging current of 0.1 ~ 0.5C

1.2 Discharge

1.2.1 Discharge current must be controlled by specified value in Cell specification.

1.2.2 Cut-off Voltage of discharging must be over 2.75V.

1.2.3 The battery can be used within the following temperature ranges.

Don't exceed these ranges.

Discharge temperature ranges : -20°C ~ 60°C (Ambient).

1.3 Storage

Store the battery at low temperature (below 60°C, 20°C is recommended), low humidity (below 65%), no dust and no corrosive gas atmosphere.

1.4 Design of positioning the battery pack in application and charger

To prevent the deterioration of the battery performance caused by heat, battery shall be

Spec. No.	ICR18650-26J	Version No.	Tentative v0.1
-----------	--------------	-------------	----------------

positioned away from the area where heat is generated in the application and the charger.

1.5 Safety Device

Be sure adopting proper safe device such as PTC specified type or model in Cell Specification. If you intend to adopt different safety device which is not specified in Cell Specification, please contact Samsung SDI to investigate any potential safety problem. Be sure designing 2nd protective devices such as PTC & PCM at the same time to protect Cell just in case one protective device is fault.

2. Design of System

2.1 Connection between Cells and the battery

- 2.1.1 Cell should not be soldered directly with other Cells. Namely, Cell should be welded with leads on its terminal and then be soldered with wire or leads to solder.
- 2.1.2 Otherwise, it may cause damage of component, such as separator and insulator, by heat generation.

2.2 Positioning the battery in the System

- 2.2.1 The battery should be positioned as possible as far from heat sources and high temperature components.
- 2.2.2 Otherwise, it may cause loss of characteristics.
- 2.2.3 The recommended space between Cells is more than 1mm.

2.3 Mechanical shock protection of the battery

- 2.3.1 The battery should be equipped with appropriate shock absorbers in the pack in order to minimize shock, which can damage Cells. .
- 2.3.2 Otherwise, it may cause shape distortion, leakage, heat generation and/or rupture and/or open circuit.
- 2.3.3 Ultrasonic should not be used when manufacturing battery packs as it can damage the connection between component parts.

2.4 Short-circuit protection of Cell

- 2.4.1 Cell is equipped with an insulating sleeve to protect short-circuit which may occur during transportation, battery assembly and /or system operation.
- 2.4.2 If Cell sleeve is damaged by some causes such as outside impact, it may cause short-circuit with some wiring inside the battery.

2.5 Connection between the battery and charger/system

- 2.5.1 The battery should be designed to be connected only to the specified charger and system.
- 2.5.2 A reverse connection of the battery, even in the specified system, should be avoided by employing special battery design such as a special terminals.

Spec. No.	ICR18650-26J	Version No.	Tentative v0.1
-----------	--------------	-------------	----------------

2.6 Pack design

2.6.1 The current consumption of the battery pack should be under 10uA at sleep mode.

2.6.2 Cell voltage monitoring system.

The system (charger or pack) should be equipped with a device to monitor each voltage of Cell block to avoid Cell imbalance which can cause damage to Cells.

2.6.3 The battery pack or system should have warning system such as over temperature, over voltage, over current, and so on.

2.6.4 Mechanical design

Item	Portable IT	Power-Tool	Medical	E-Bike	E-Scooter	EV/LEV	ESS/UPS
<input type="checkbox"/> Need partitions(separator) between BMS and a Cell	◎	◎	◎	◎	◎	◎	◎
<input type="checkbox"/> Need to check if the pack is designed to be able to avoid thermal runaway (1KWh ↑)					◎	◎	◎
<input type="checkbox"/> Need to analyze the battery pack's thermal distribution and its effect on the pack's life cycle					◎	◎	◎
<input type="checkbox"/> Need to use a non-flammable (VO level) case	◎	◎	◎	◎	◎	◎	◎
<input type="checkbox"/> Need to apply improved material (Steel) to the case						◎	◎
<input type="checkbox"/> Need to analyze the battery pack's structure, system, installation status and use environment						◎	◎

Spec. No.	ICR18650-26J	Version No.	Tentative v0.1
-----------	--------------	-------------	----------------

Handling precaution and prohibitions of lithium-ion rechargeable Cells and batteries

Inaccurate handling of lithium ion and lithium ion batteries rechargeable battery may cause leakage, heat, smoke, an explosion, or fire.

This could cause deterioration of performance or failure. Please be sure to follow instructions carefully.

1. Safety precaution and prohibitions

To assure product safety, describe the following precautions in the instruction manual of the application.

2. Danger

2.1 Electrical misuse

2.1.1 Use dedicated charger.

2.1.2 Use or charge the battery only in the dedicated application.

2.1.3 Don't charge the battery by an electric outlet directly or a cigarette lighter charger.

2.1.4 Don't charge the battery reversely.

2.2 Environmental misuse

2.2.1 Don't leave the battery near the fire or a heated source.

2.2.2 Don't throw the battery into the fire.

2.2.3 Don't leave, charge or use the battery in a car or similar place where inside of temperature may be over 60°C.

2.2.4 Don't immerse, throw, wet the battery in water / seawater.

2.3 Others

2.3.1 Don't fold the battery cased with laminated film such as pouch and Polymer.

2.3.2 Don't store the battery in a pocket or a bag together with metallic objects such as keys, necklaces, hairpins, coins, or screws.

2.3.3 Don't short circuit (+) and (-) terminals with metallic object intentionally.

2.3.4 Don't pierce the battery with a sharp object such as a needle, screw drivers.

2.3.5 Don't heat partial area of the battery with heated objects such as soldering iron.

2.3.6 Don't hit with heavy objects such as a hammer, weight.

Spec. No.	ICR18650-26J	Version No.	Tentative v0.1
-----------	--------------	-------------	----------------

- 2.3.7 Don't step on the battery and throw or drop the battery on the hard floor to avoid mechanical hock.
- 2.3.8 Don't disassemble the battery or modify the battery design including electric circuit.
- 2.3.9 Don't solder on the battery directly.
- 2.3.10 Don't use seriously scarred or deformed battery.
- 2.3.11 Don't put the battery into a microwave oven, dryer ,or high-pressure container.
- 2.3.12 Don't use or assemble the battery with other makers' batteries, different types and/or models of batteries such as dry batteries, nickel-metal hydride batteries, or nickel-cadmium batteries.
- 2.3.13 Don't use or assemble old and new batteries together.

3. Warning

- 3.1 Stop using the battery if the battery becomes abnormally hot, odor, discoloration, deformation, or abnormal conditions is detected during use, charge, or storage.
- 3.2 Keep away from fire immediately when leakage or foul odors are detected. If liquid leaks onto your skin or clothes, wash well with fresh water immediately.
- 3.3 If liquid leaking from the battery gets into your eyes, don't rub your eyes and wash them with clean water and go to see a doctor immediately.
- 3.4 If the terminals of the battery become dirty, wipe with a dry cloth before using the battery.
- 3.5 Cover terminals with proper insulating tape before disposal.
- 3.6 Vape or E-cigarette devices warning
 - 3.6.1 Samsung SDI's cells are not designed or manufactured for use in any vape or e-cigarette devices.
 - 3.6.2 Samsung SDI's cells are designed for use and to be incorporated in a battery management unit that reduces the risk of thermal runaway.
 - 3.6.3 Samsung SDI's cells are not designed for and should not be handled by any individual consumer.
 - 3.6.4 Samsung SDI did not authorize any third parties, including vape or e-cigarette device manufacturers, retailers and distributors to sell or use Samsung SDI's cells for individual consumers as power sources in e-cigarettes or vape devices.
 - 3.6.5 Any online e-commerce sales, sales to individual consumers, or sales to third parties for such purpose are strictly prohibited.

Spec. No.	ICR18650-26J	Version No.	Tentative v0.1
-----------	--------------	-------------	----------------

4. Caution

4.1 Electrical misuseage

Battery must be charge with constant current-constant voltage (CC/CV).

4.2 Others

4.2.1 Keep the battery away from babies and children to avoid any accidents such as swallow.

4.2.2 If younger children use the battery, their guardians should explain the proper handling method and precaution before using.

4.2.3 Before using the battery, be sure to read the user's manual and precaution of its handling.

4.2.4 Before using charger, be sure to read the user's manual of the charger.

4.2.5 Before installing and removing the battery from application, be sure to read user's manual of the application.

4.2.6 Replace the battery when using time of battery becomes much shorter than usual.

4.2.7 Cover terminals with insulating tape before proper disposal.

4.2.8 If the battery is needed to be stored for an long period, battery should be removed from the application and stored in a place where humidity and temperature are low.

4.2.9 While the battery is charged, used and stored, keep it away from object materials with static electric chargers.

5. Safety Handling Procedure for the Transporter

5.1 Quarantine

Packages that are crushed, punctured or torn open to reveal contents should not be transported. Such packages should be isolated until the shipper has been consulted, provided instructions and, if appropriate, arranged to have the product inspected and repacked.

5.2 Spilled Product

In the event that damage to packaging results in the release of Cells or batteries, the spilled products should be promptly collected and segregated and the shipper should be contacted for instructions.