

MEMORY BACKUP BATTERY - LITHIUM

SPECIFICATIONS

Model	:	CR2032-1GV
Description	:	Lithium Coin Cell (LiMnO ₂), Mercury Free
Norminal Capacity	:	210mAh at 30K Ohm continuous discharge
Nominal Voltage	:	3.0 V
Cut-Off Voltage	:	2.0 V
Weight	:	3.4 g
Self-Life	:	3 years ex-factory
Recommended Drain	:	Pulse - 15mA Standard - 0.5mA Low - 0.004mA
Maximum Drain	:	Continuous - 3mA
Service Life	:	1150 hrs at 15K Ohm continuous discharge 2310 hrs at 30K Ohm continuous discharge
Application	:	Memory Backup, Electronic Watches, Calculators, Cameras, Electronic Translators, Low Power Cordless Application

Typical Discharge Characteristics

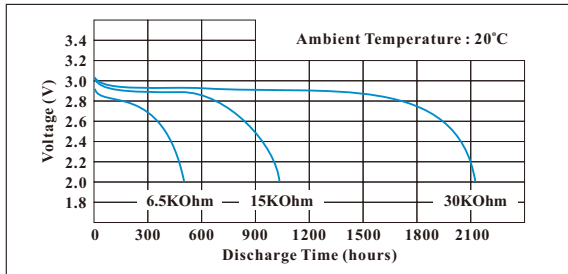

Typical Discharge Characteristics

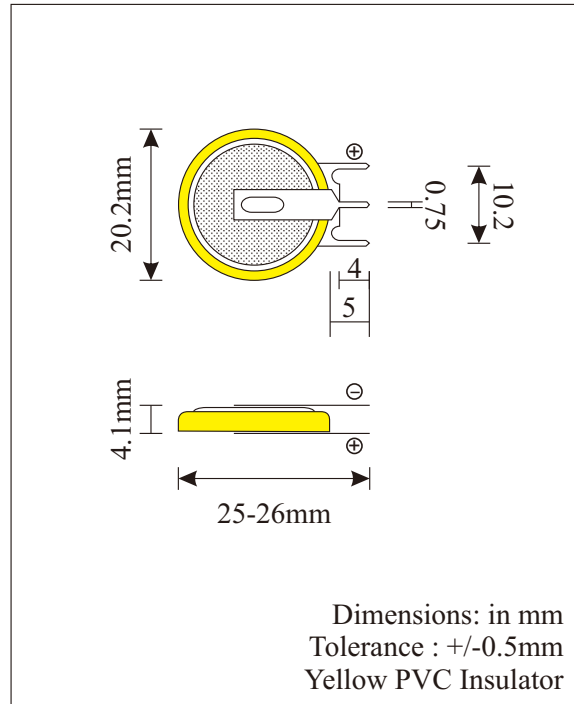
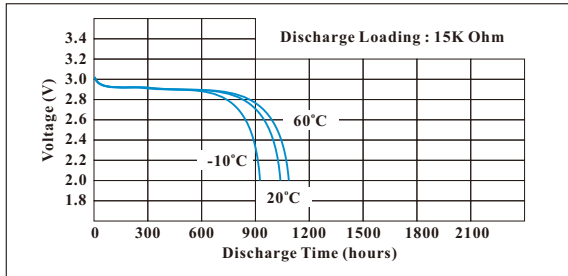

Typical Discharge Characteristics

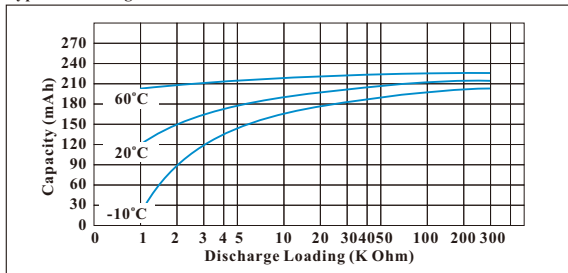

Typical Discharge Characteristics (Pulse Discharge)

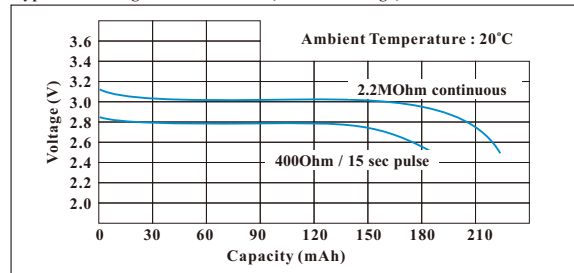

Information is for references only.